

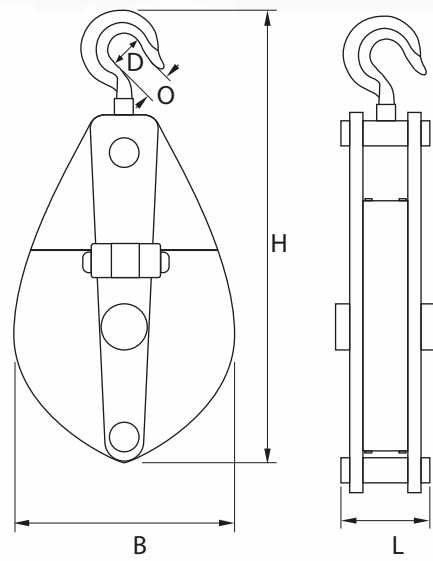

# PASTECA SIMPLE ABIERTA CON GANCHO

## ESPECIFICACIONES



Cod. Ref.	Dimensiones (mm)					Carga de trabajo	Peso
	H	B	L	D	O	Ton.	Kg.
PH10A	260	98	61.5	31.5	>=22	0.899	1.8
PH101	310	116	70.5	37.5	>=27	1.798	4.03
PH102	405	152	88	45	>=32	3.596	7.4
PH103	470	176	101	50	>=37	5.755	12.16
PH105	570	212	117	60	>=42	8.992	22.82
PH108	730	280	141	75	>=56	14.387	38.93
PH110	810	316	159	85	>=61	17.984	60.92
PH116	1010	406	185	106	>=81	25.178	107.16
PH120	1150	452	193	118	>=90	31.473	152.15

Preparado por: **REPRESENTANTE GERENCIA**      Revisado por: **GERENTE PRODUCCIÓN Y OPERACIONES**      Revisado por: **GERENTE GENERAL**

**PRODUCTO CERTIFICADO**

**SANTIAGO**  
Av. Miraflores 9440,  
Pudahuel.  
Santiago de Chile  
+56 2 27733726  
ventas@socadin.cl

**COPIAPÓ**  
Panamericana Norte 811,  
Plaza Comercio Local 18  
Copiapó, Chile  
+569 99 650 600  
ventascopiapo@socadin.cl

**ANTOFAGASTA**  
Av. Industrial N° 7280,  
Centronor Local 11  
Antofagasta, Chile  
+569 8917 0716  
ventasantofagasta@socadin.cl

**SOCADIN®**  
GRUPO ATLAS CHILE®  
www.socadin.cl

Código: ESPRO-359  
Fecha: 18/11/2020  
Versión: 05